

Time to meet up.

## The art of mastering new demands and exceeding expectations.

As time becomes evermore precious, efficient and successful meetings become evermore important. Successful meetings allow us to connect with the other participants, and to present ourselves and our company. And our stuff... Because, even though its practical advantages were what determined the purchase, rolling in a large interactive whiteboard that includes a projector probably gives one a special feeling, **page 8**. And it can only get better when you set the display height for the audience by remote control. Not to mention how practical it can be to have access to full mobile videoconference equipment, equipped with double screens and a camera, **page 20**. This catalogue presents a selection of our new products and applications to ensure successful meetings. We hope you enjoy the catalogue, and we look forward to seeing you soon.

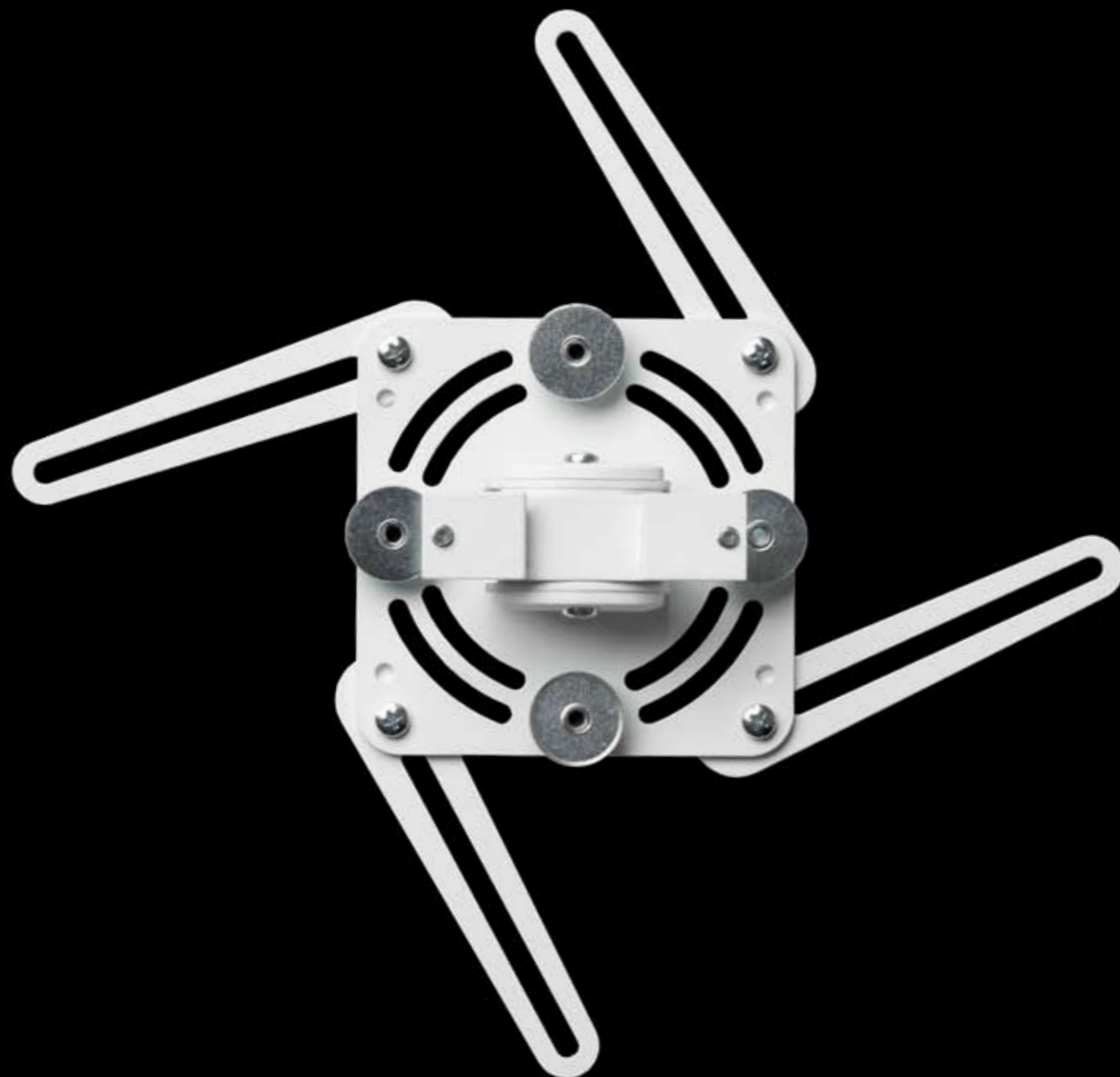



**New!**

Always in stock. And always a match. One single product. Our new Unislide for short-throw projectors has had much praise. A good image can be transformed quickly into the perfect image with the aid of the four fine-adjustment screws. There's no need to have special versions in stock for different manufacturers since the slide fits most projectors (and it is available in black or white, allowing it to be matched in colour).

**Updated!**



Even more attractive.



The column can be adjusted both vertically and horizontally.

An integral cable holder, now also available in white.

**SMS PROJECTOR WL SHORT THROW V+.** This wall bracket not only offers an extraordinary range of adjustments – with fine-adjustment screws on the slide and the vertical and horizontal adjustment at the wall plate – it also offers state-of-the-art surface finishes. The new material used for its manufacture, extruded aluminium, gives a stylish appearance, lower weight (approximately half of the previous weight) and dimensions that are small enough to allow the wall bracket to be easily fixed, where necessary, close to the ceiling. The bracket is available in black or white, and is equipped with an integral cable holder as standard.



Available in several lengths, dependent on projector model.



**SMS PROJECTOR SHORT THROW MOBILE MOTORIZED**  
The conference that can fit into the lift. Superb flexibility allowing you to take your complete "projector room" with you on wheels: motor-driven height adjustment allows you to get through low doors, and the ability to rotate the column head means that everything fits into the lift. The SMS Projector Short Throw Mobile Motorized is compatible with most projectors and interactive whiteboards.

Get through narrow spaces. Many premises have narrow doors. That's why we have developed a rotatable column head for the SMS Projector Short Throw Mobile Motorized that quickly makes the unit more compact.

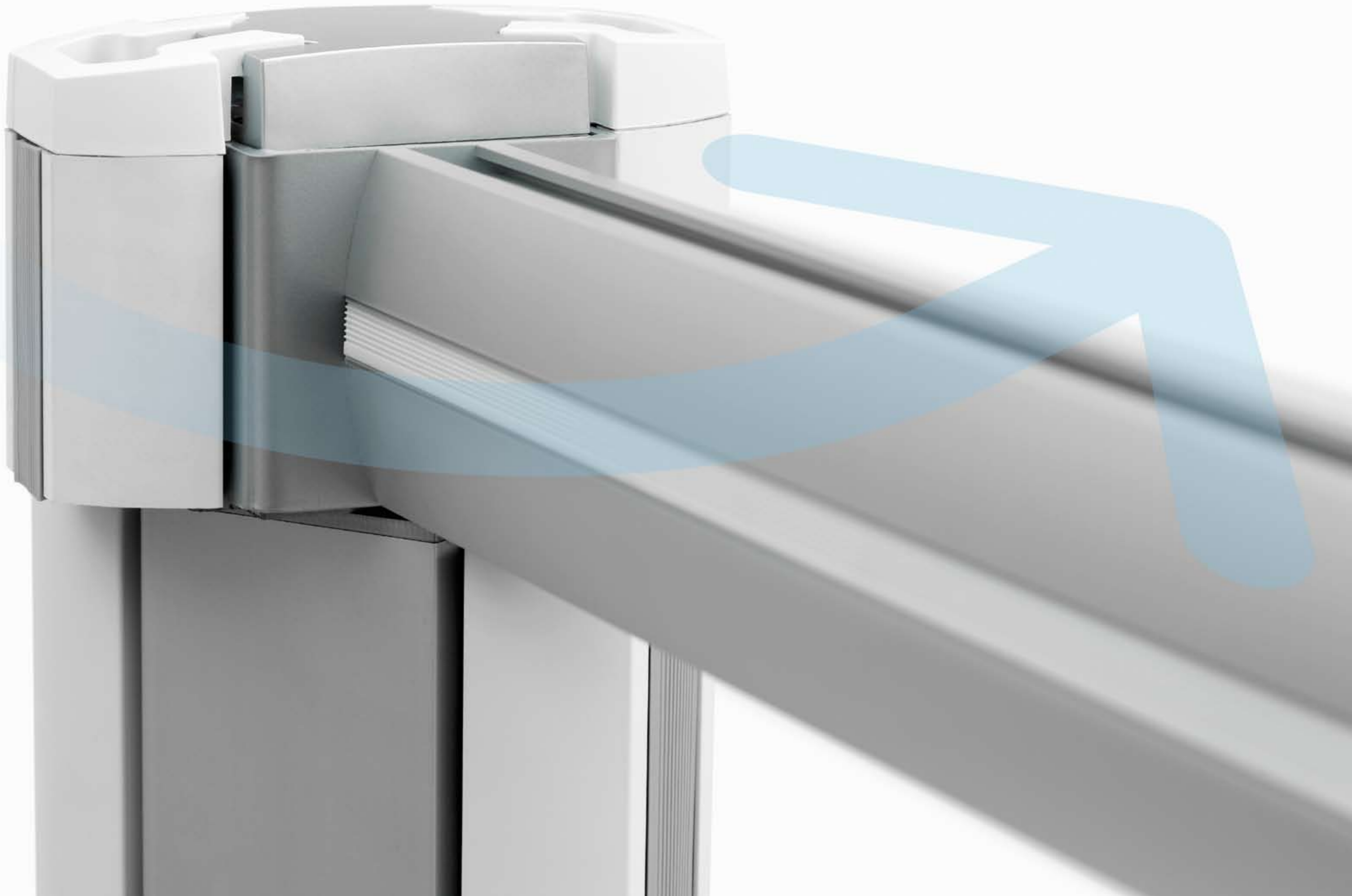

# Increased participation in presentations and lessons.

**SMS PROJECTOR SHORT THROW WALL MOTORIZED.** It is sometimes necessary to adapt the viewing height – perhaps due to the height of the audience, or for other reasons. We now have the perfect solution for anyone who needs a fixed installation while at the same time requiring flexibility. The main column can be electrically raised and lowered, enabling this stand to be adjusted from one situation to another with a simple button press. This is an ideal facility, not least for when seminar participants or pupils need to come up to the screen to point or make their own presentations. Can be used with most projectors and interactive screens.



## WHAT IS AN INTERACTIVE SCREEN?

An interactive screen is pressure-sensitive, making it possible to control a computer from the screen by, for example, using a finger as a computer mouse. This is achieved technically by connecting a computer to a video projector, which then illuminates the screen using a program that can interpret touch patterns. The solution combines teaching advantages with the presentation possibilities and storage facilities of the computer.

Proved to offer more efficient learning. A study carried out at the Manchester Metropolitan University showed that pupils who used an interactive screen during teaching of three major subjects achieved an educational advantage of several months over pupils who did not.

- Optimal viewing height and angle due to the ability to raise and lower the main column electrically.
- Automatic control with wired remote (wireless control is available as an option).
- Integral electrical power socket in the main column facilitates connection and cable management.
- Many adjustments to ensure that the image projection is perfect.

SMS PROJECTOR SHORT THROW WALL MOTORIZED. Art no: AE019001-P0

A fixed installation with high flexibility due to the ability to raise and lower the main column electrically.

? Need help in choosing a bracket? See Page 42. + Technical information is available at [www.smartmediasolutions.se](http://www.smartmediasolutions.se)

Konferens 7A need technology, premises and furniture that are as flexible as they are exclusive.

## “What we offer is based on location, reception and drive.”



How does a modern conference organiser experience the customers and their needs? SMS has interviewed Bo Fuglsang, Marketing Manager at Konferens 7A, a company whose ambition is to create exactly the surroundings that the customer wants. Bo Fuglsang expresses this precisely when he says that they are “always rearranging the furniture”. Their exclusive address on Strandvägen in Stockholm exerts a certain force of attraction, given its central location and the beautiful surroundings; while the aim of the company is to create a feeling of entering someone’s home, rather than a conference facility.

There are no “meeting rooms” here, just room after room of beautiful, airy fittings, open fireplaces and the feeling of a wealthy city-centre penthouse. But under all of the classical beauty, with its ornaments, mirrors and chandeliers, there broods an ingenious flexibility. The rooms can be rapidly divided to form rooms of suitable size, and the massive hardwood tables can be easily rearranged to give anything from small stylish tables to a table fit for a board meeting. It is just this combination of exclusive surroundings and high flexibility that has shown that it can attract companies of widely different natures.

### From courtroom to catwalk

“We may have a company here one day arranging a large customer seminar, while the next day we may have two parties starting a three-week civil court case. Or it may be the Swedish fashion and decorating retailer Indiska who are here, turning the place into a catwalk”, says Bo Fuglsang. The sales meeting will probably need projectors and a classroom-type arrangement. The legal folk, in contrast, will construct a court, bring in tonnes of files and connect dozens of computers, while the fashion house will require all the advanced sound, vision and lighting equipment that characterises a hyped-up fashion show.

“Nearly everything here is on wheels,” says Bo Fuglsang, “from heavy furniture and large flatscreen monitors down to side tables and pot plants. This is to make it easy for the personnel and also to save time.”

### Roll in the new

Conference clients today place high demands on visualising images, and Konferens 7A has noticed increased requirements for everything from high-quality projectors to large screens. “The new interactive

screens are a very attractive alternative, particularly in combination with a wheeled stand that can be easily rolled into our lifts, and whose height can be regulated.”

“There is an increasing demand for meetings that are sensitive to the environment; and as globalisation increases, videoconferences are becoming evermore interesting.” An important component of environmentally sensitive meetings is the food served. Konferens 7A is currently drawing up a new environmental policy, and is considering the possibility of offering locally produced and ecologically certified meals. Carbon-offset meetings are also on the agenda.

### Successful conferences

“The watchword for a successful conference is ‘hassle-free’. We always have a computer technician on hand, because when the place is stuffed with technology it’s not reasonable to expect that the conference personnel be responsible for getting the network or projector to work.” It is important to provide good information, so that the visitors feel secure and well taken care of, they must not feel that they are in an unfamiliar place. And it’s important to be proactive.

“The perfect conference host is not the one who ‘becomes invisible’, but the one who is prepared to talk to the guests, to find out whether they are comfortable or if they lack anything. That way you ensure that everything is under control, and this may be the extra little something that makes a difference. Such as suddenly arriving with a large bowl of sweets, to kick-start a group that has got stuck on the last point in the agenda and give the participants the energy needed to complete the task.

That’s what I call ‘power-point’.”







Customer adaptation. Conference clients today place high demands on visualising images. Mobility is also important for Konferens 7A, which is why they have invested in, among other things, the SMS Flatscreen X FH M.

# Our professional series has been X-tended with X-tra modular design.

This is really where we can talk about long-term solutions – add or exchange a single item and the product can suddenly solve completely new tasks. Our newly extended X series gives the user hitherto unknown possibilities to create combinations based on current needs, and to adapt to future needs. A modular design means that a single basic profile (the main column) and a few ingenious accessories allow the system to cover all possible requirements. These may include, for example, mobility, storage, the ability to mount the screen vertically or horizontally, or several screens back-to-back. This is state-of-the-art, and it is also so simple and obvious!

**New!**



### SMS X MEDIA BOX

It is possible to mount just the accessories required along the two sides of the main column, giving a solution that corresponds exactly to the display requirements. The accessories may include, for example, the SMS X Media Box with an integral data rack and locking cover, for practical storage and concealment of peripherals. Select the version with wheels and you can take your equipment to the audience, not the other way round.



### "THE SKY IS THE LIMIT"

Air traffic controllers, share dealers and others who require an overview that exceeds normal requirements can now mount several screens both in width and in height, based on the X column.



### SMS X SHELVES. SMS X REMOTE CONTROL KIT

Sometimes all you need is something as practical and basic as a shelf to put your papers on. A hand control is included in our motorised stands. Wireless remote control is available as an option.



### DOWNLOAD!

The brochure "Long-term impressions" presents our extended X series. Download the brochure from: [www.smartmediasolutions.se](http://www.smartmediasolutions.se)



The Hamburg Climate Week was held in September 2009, and many X series stands of various configurations were installed.



**New!**

A stand that is always the centre of attention. When the visitors and passers-by come from many directions – at trade fairs, in hotel lobbies, or in other public places – it's not always easy to know which way to face. This mobile three-way display is based on our X series.



**New!**

A videoconference on wheels. Equipped with double 46" screens and a top-mounted camera, this is one of many examples of the possibilities of the professional X series and its modular design.



Did you know... that it is easy for a stand to work in two different directions? This application idea comes from our distributor in Dubai, using in an optimal manner the opportunities provided by the column design to mount screens both at the front and back and at different heights.

# Digital meetings.

The word “meeting” can be extended to refer to any encounter with the target group, wherever it may be located. Robust equipment may sometimes be needed for such meetings. In other situations, it’s a question of screens and similar equipment that can blend into the surroundings, and here it is style and good taste that are important. Sometimes, both robust construction and the right appearance are required. We are now taking the step towards offering a broad comprehensive solution within Digital Signage – the SMS Media Cabinet Extreme.



## SMS MEDIA CABINET EXTREME

Our Media Cabinet range now includes a standard product for outdoor use – the Extreme package. Armoured glass from the Swedish company Hammerglass is standard.  
Art no: MC010-series

## CUSTOM MADE

SMS sells more than products, we have always believed in listening to the customer and having a broader perspective than our current range. Many new and exciting solutions have been developed through the years at the request of, and in close collaboration with, our customers. In our striving to nurture the relationship between our personnel and our customers, we are increasing the opportunities to tailor a solution to your exact needs, either by combining existing product modules or, quite simply, by one of our engineers sitting down with you and a blank sheet of paper. We are open to most suggestions, so don't hesitate to contact us.

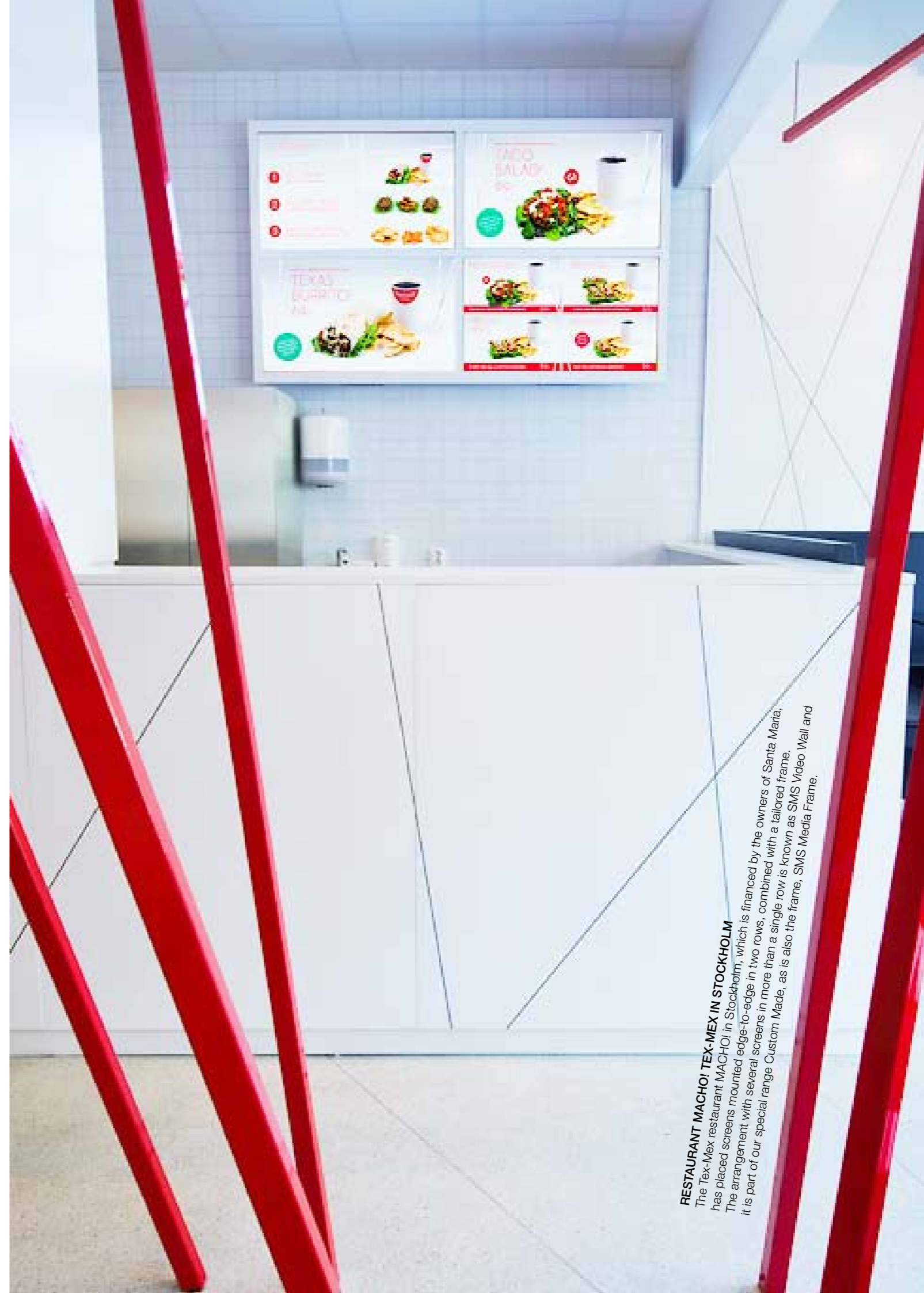

**RESTAURANT MACHOI TEX-MEX IN STOCKHOLM**  
The Tex-Mex restaurant MACHOI in Stockholm, which is financed by the owners of Santa Maria, has placed screens mounted edge-to-edge in two rows, combined with a tailored frame. The arrangement with several screens in more than a single row is known as SMS Video Wall and it is part of our special range Custom Made, as is also the frame, SMS Media Frame.



**TELENOR, STOCKHOLM CITY**

This installation contains screens mounted along a row with tailored farming, and is part of our Custom Made range. This product is known as SMS Video Row, and was delivered by Instoremedia AB.

**YEAR-ROUND SECURITY AT THE SKI RESORT.**

We have installed the SMS Media Cabinet Extreme at Åregården in Åre, Sweden. Temperatures of  $-25^{\circ}\text{C}$  are not unusual here.



COOP EXTRA, MEDBORGARPLATSEN IN STOCKHOLM  
SMS Video Row and SMS Media Frame are used to present  
menus and prices at the new lunch restaurant in the food store.



### Meny kaffe&Te

	Stor/Var
Varmt kaffe	15,-/14,-
Espresso	10,-/10,-
Caffelatte	10,-/10,-
Cappuccino	10,-/10,-



Med ekologisk mjölk  
1 liter kaffe 15,-

## GREEN ROOM

CAFE & TAKE AWAY

### Dagens lunch

Väget lunch  
\* Kalkylkostad  
med ekologisk grönsaker  
och bröd till 15,-

\* Havsrecept  
med ekologisk fisk  
och smörgåsar till 15,-

Väget lunch  
med ekologisk fisk  
och smörgåsar till 15,-

79:-

75:-





## Start with coffee – a smart move.

The Swedes are world champions in drinking coffee. This was also true during the 1960s, when von Brömsen, who later would found the company Svenska Monitor Stativ (SMS), was granted a patent for “Nicke” – a wooden stand suitable for all coffee pots available at the time. The playfully simple and flexible “accordion” design fit the coffee pot exactly, and was soon widespread throughout Sweden. Read about the history of SMS from the first tiltable TV-stand to our current products for digital signage and short-throw projectors.

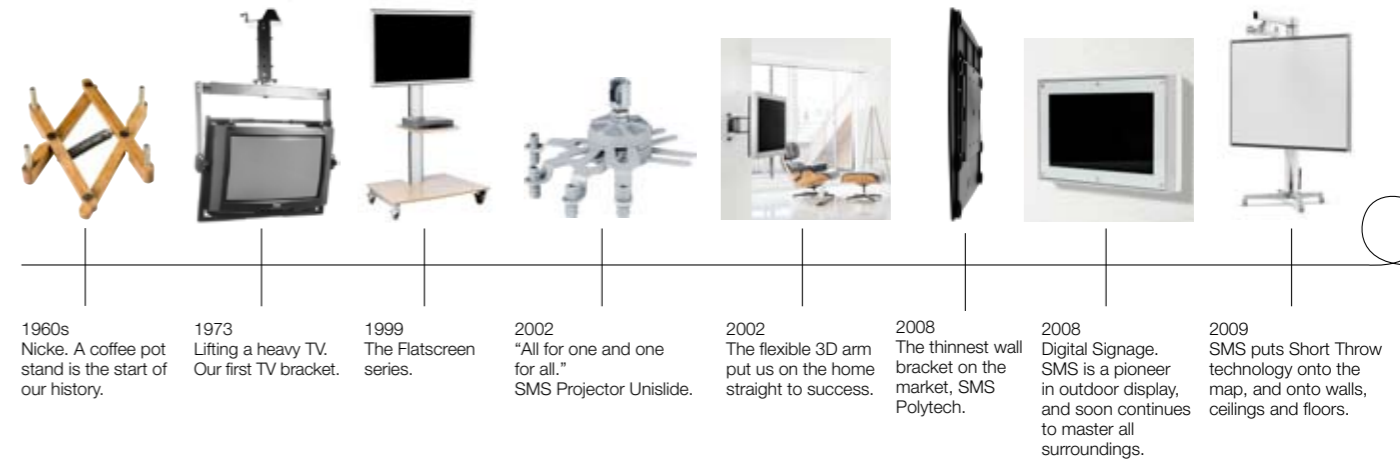

Nicke was later taken over by von Brömsen’s son, one of whose further developments of the product was to manufacture it from plastic. At the same time as today’s modern coffee machines were taking over the market, the older von Brömsen, who despite his success was not ready to settle down quietly, received a request from a head teacher at one of the schools in Stockholm. Could he develop a product for suspending a TV in the classroom so that all pupils could see it at the same time?

Von Brömsen used the same flexibility that had characterised Nicke in the new product. He developed a bracket that not only held the heavy TV set aloft, but also made it easy and safe to rotate and tilt, by placing a tilt mechanism under the centre of gravity of the set. von Brömsen reckoned that it should be possible to develop further products from the same basic idea, and his company was subsequently successful in dominating the Swedish market for TV brackets.

I took over as managing director of the company in 1996, with the intention of expanding abroad. We gradually built up a network of independent distributors. The name Svenska Monitor Stativ was pretty much impossible for many of our partners abroad to pronounce, and so the name was shortened to SMS. The meaning was at the same time changed to become Safe Brackets Made in Sweden AB, in order to emphasise that the company was producing safe brackets. The brackets at this time were solely intended for installation in public areas.

Draper Inc. bought the company in January 2000, and the name was changed to Safe Bracket AB. This meant that the abbreviation no longer had

any significance. By 2003 operations had been broadened such that they covered modules for digital signage in addition to brackets for flatscreen monitors and projectors, and the name issue had become as troublesome as chewing gum under one’s shoe!

And the Safe Brackets name did not become any less misleading when we launched one of our most creative and innovative products for many years. A large Swedish municipality had expressed a need to use digital signage within the public transport system, and asked SMS for details. We saw the potential for a new market and it was fortunate that we invested in developing the technology required, even though the municipality never actually placed an order.

It wasn’t long before the first order for what later came to be called Media Cabinets arrived – from the ski resort Sälen. They saw the possibilities offered by being able to inform guests rapidly which lifts are open, give details of events, etc. The Media Cabinet, together with the Short Throw bracket, is today our most rapidly growing product area, and we stand in the starting blocks ready to keep pace with global technological development, and ready for a long line of exciting innovations. So what happened with that pesky question about the name? We took our current company name in 2006 and the abbreviation once again achieved a meaning that is worthy of the name: Smart Media Solutions.

Dan Berglund  
Managing director



# SIMPLICITY. PRECISION. FLEXIBILITY.

## OUR PROFESSIONAL RANGE – THE X RANGE.

If anyone knows how important it is with the right attitude, it's you. Everything should be just one click away. The X Series is based on the conviction that each detail is an important part of your presentation. That's why we have functions and adjustment facilities that make the job so simple that anyone can see that this presentation is the work of a professional.

ONE WEIGHT CLASS IS AVAILABLE

SMS Flatscreen X FH/WH/CH



### VERTICAL OR HORIZONTAL?

Our unique Unislide enables large screens to be pivoted in stepless increments.

SMS FLATSCREEN X H UNISLIDE  
Art no: PD210-series



### FULLY MOBILE

Wheels for mobility, lockable for safety.

SMS FLATSCREEN X FH M  
Art no: PD031-series



DVD or PC at your fingertips. Locking door and space for a computer rack give added security. Available in walnut, oak or white.

SMS X Media Box  
Art no: PD400-series



Gracile storage with shelves of various finishes and materials. Available in walnut, oak or white.

SMS X Shelves  
Art no: PD300-series



**Download!**



Download the X Series brochure.  
[www.smartmediasolutions.se](http://www.smartmediasolutions.se)

### NB!



Conceal all the cables with SMS Cable Management. See Page 35.



### STYLISH FROM HEAD TO FOOT

Choose a foot – as stable as it is gracile – for the best possible appearance.

SMS FLATSCREEN X FH  
Art no: PD041-series

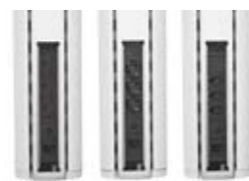

Electrical power sockets can be mounted at the rear.



### ATTACHED TO THE WALL AND FLOOR

Mount the column between the wall and the floor, and become less dependent on the structure of the wall.

SMS FLATSCREEN X WFH S  
Art no: PD091-series



### CEILING MOUNTING

Provides great freedom, since it gets the screen out of the way. The mounting is independent of walls and it does not take up floor space. It is also possible to display your message in more than one direction by mounting two screens back-to-back.

SMS FLATSCREEN X CH S  
Art no: PD061-series



### ATTACHED SOLELY TO THE WALL!

This solution allows you to mount your screen vertically or horizontally in any surroundings.

SMS FLATSCREEN X WH S  
Art no: PD081-series



## SMS PROJECTOR X



Mount the projector with a click, and remove it for safe storage just as simply.



Swivel or tilt for exact adjustment.



### IT'S EASY TO GET OVER A LOW CEILING.

Mounting the projector close to the ceiling allows projectors to be used with low ceilings.

SMS PROJECTOR X CL F75  
Art no: AE015-series



Available in white or black.

### FOR PROFESSIONALS

You experience it through the many built-in functions and the wide range of independent adjustments.

SMS PROJECTOR X CL F  
Art no: AE015-series



- The most flexible and easy-to-use products for professionals.
- Finish and adjustment facilities improve image quality and the overall impression.
- Shelves and other practical accessories to collect and conceal peripherals.

? Need help in choosing a bracket? See Page 42. + Technical information is available at [www.smartmediasolutions.se](http://www.smartmediasolutions.se)

# THE CEILING BRACKET THAT ENSURES THE PRESENTATION IS AT THE RIGHT HEIGHT.

Ceiling mounting gives great freedom, since it gets the screen out of the way. The mounting is independent of walls and it does not take up floor space. It is also possible to display your message in more than one direction by mounting two screens back-to-back.

THREE WEIGHT CLASSES ARE AVAILABLE

**?**

SMS Flatscreen CH/CM/CL

**HEAVY WEIGHT, H**  
100 kg -37-50"

**MIDDLE WEIGHT, M**  
30 kg -26-37"

**LIGHT WEIGHT, L**  
15 kg -15-26"

Compact fixture to the ceiling.

USE THE LENGTH YOU NEED  
600, 1150, 1450 or 2000 mm.

SMS FLATSCREEN CH ST  
Art no: PL061-series

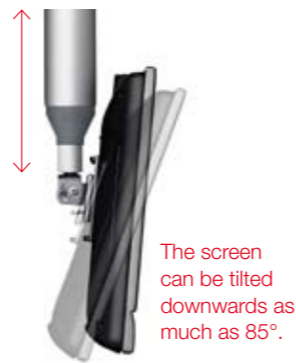

EXTEND TO THE DESIRED LENGTH

Available in the following lengths:  
300-350, 500-750, 650-900,  
850-1100 and 1050-1300 mm.

SMS FLATSCREEN CL VST  
Art no: FS021-series



FOUR SCREENS!

SMS FLATSCREEN CL/CM ST  
Art no: FS061-series



**NB!**



Conceal all the cables with SMS Cable Management. See Page 35.

DOUBLE SCREENS  
Mounted back-to-back.

SMS FLATSCREEN CH STD  
Art no: PL061-series



TALK ABOUT TILTING

The screen can be swivelled through +/-180° and tilted approximately +10°/-3°.

- Fixing the screen to the ceiling gets it out of the way.
- Flexible with ample adjustment possibilities for one or several screens.
- Can support back-to-back displays.

# YOUR MESSAGE WILL REACH FURTHER WITH OUR COLOUR-COORDINATED 3D ARMS.

These popular 3D arms blend into all surroundings due to Cable Management and the availability of three colours.

GLOSSY WHITE



SMS FLATSCREEN WL 3D  
WM 3D/WH 3D

Art no: FS041-series  
FS041-series  
PL101-series

PIANO BLACK



DARK GREY



**NB!**

The integration becomes complete with a well-concealed outlet for SMS Cable Management underneath the 3D arm.

SMS Cable Management  
Art no: CM010001/CM010002

**?** Need help in choosing a bracket? See Page 42. **+** Technical information is available at [www.smartmediasolutions.se](http://www.smartmediasolutions.se)

# A WALL BRACKET WITH MANY ANGLES.

You can install nearly any screen at all in any surroundings using one of our wall brackets with suitable accessories. Fix it directly on the wall or with a small gap, mount it against the floor or the ceiling.

THREE WEIGHT CLASSES ARE AVAILABLE

**?**

SMS Flatscreen WH/WM/WL

**HEAVY WEIGHT, H**  
100 kg -37-50"

**MIDDLE WEIGHT, M**  
30 kg -26-37"

**LIGHT WEIGHT, L**  
15 kg -15-26"

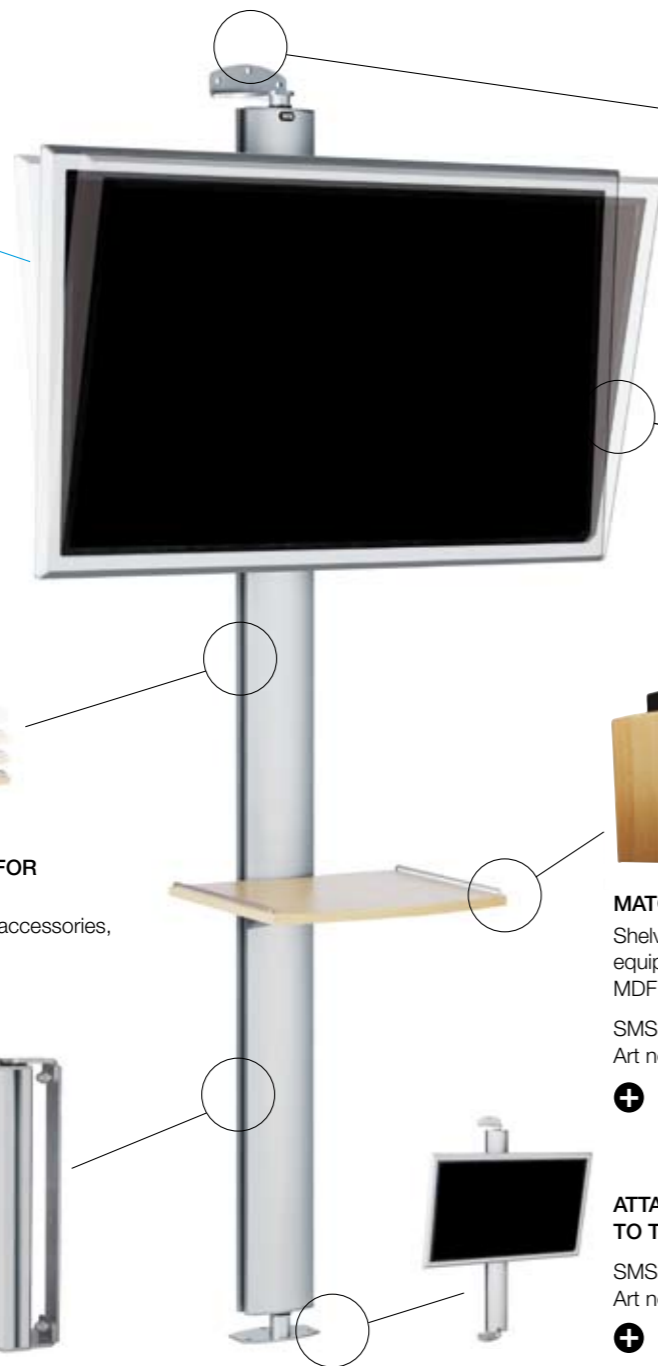

**ATTACHED TO THE WALL AND FLOOR!**

Mount the column between the wall and the floor, and thus become less dependent on the structure of the wall.

SMS FLATSCREEN WFH ST  
Art no: PL091-series



**TILT FOR AN IMPROVED IMAGE**

Place the screen at stepless increments of height and tilt it to obtain the best viewing angle.

**STEPLESS INCREMENTS FOR GREATER POSSIBILITIES**

Space for shelves and other accessories, freely adjustable in height.



**MATCH YOUR DECOR**

Shelves for DVD or other peripheral equipment. Manufactured from sturdy MDF board or transparent Plexiglas.

SMS SHELVES H/M/L  
Art no: FS040-series/SU010-series



**ATTACHED SOLELY TO THE WALL**

SMS FLATSCREEN WH ST  
Art no: PL081-series



**PERFECT FOR CONCRETE COLUMNS**

A support that is as stable as it is flexible for screens up to 75 kg. Allows the screen to be swivelled and tilted, and allows its height to be adjusted.

SMS FLATSCREEN WH ST  
Art no: PL081-series



**NB!**



Conceal all the cables with SMS Cable Management. See Page 35.



**SEVERAL SCREENS**

If you need to support up to three screens or a combination of screens and shelves. The screen can be swivelled and tilted.

SMS FLATSCREEN WL/WM ST800  
Art no: FS051-series



Everything you need to mount an extra screen on the bracket. Provides tilt and swivel functions for the screen.

SMS FLATSCREEN L/M ST KIT  
Art no: FS040011, FS040017



**TILT FACILITY WITHOUT PROTRUSION**

Flat against the wall. Partial aluminium finish, with the possibility of tilting the screen forwards.

SMS FLATSCREEN WM/WH T  
Art no: FS012001/PL021001



The screen can be tilted 10° forwards.



**Updated!**

**SMS FLATSCREEN WL ST. A TRIM BRACKET THAT GIVES THE RIGHT ANGLE.**

An unobtrusive bracket with good adjustment facilities for small screens. Available in three colours.

SMS FLATSCREEN WL ST  
Art no: FS041016  
FS041017  
FS041018



PIANO BLACK

DARK GREY

GLOSSY WHITE

- Master all environments and display at any height using SMS wall brackets and accessories.
- Can be mounted on a wall, between a wall and the floor, or between the ceiling and the floor.
- Optimal adjustment possibilities.
- A very stable solution that can support heavy weights.

**?** Need help in choosing a bracket? See Page 42. **+** Technical information is available at [www.smartmediasolutions.se](http://www.smartmediasolutions.se)

# INCREASE FREEDOM WITH A FLOOR STAND.

Our floor stands are available in all possible combinations. With wheels or feet. For light weight, middle weight and heavy weight screens. All models have adjustment facilities that ensure the best possible image viewing.

### THREE WEIGHT CLASSES ARE AVAILABLE

**HEAVY WEIGHT, H**  
100 kg ~37-50"

**MIDDLE WEIGHT, M**  
30 kg ~26-37"

**LIGHT WEIGHT, L**  
15 kg ~15-26"



**TILT FOR AN IMPROVED IMAGE**  
Possibility to tilt the screen (or two parallel screens) to obtain the optimal viewing angle.



**MATCH YOUR DECOR**  
Shelves for DVD or other peripheral equipment. Manufactured from sturdy MDF board or transparent Plexiglas.

SMS SHELVES H/M/L  
Art no: FS040-series/SU010-series

**SWIVEL AND TILT**  
A graceful floor stand for screens up to 30 kg. Fittings for shelves. The screen can be swivelled and tilted.

SMS FLATSCREEN FL/FM MST  
Art no: FS091-series

**STEPLESS INCREMENTS FOR GREATER POSSIBILITIES**  
Space for accessories, freely adjustable in height.

**FOOT WITH MOST ATTRACTIVE APPEARANCE**  
Choose a foot – as stable as it is graceful – for the best possible appearance.

SMS FLATSCREEN FH T  
Art no: PL041-series

**FULLY MOBILE**  
Wheels for mobility, lockable for safety.

SMS FLATSCREEN FH MT  
Art no: PL031-series

- The floor stand allows you to determine the location and the height of the screen.
- Mount several screens on the same stand (possible for certain models).
- Excellent adjustment flexibility, and an integral cable holder.

# THERE'S ALWAYS PLACE FOR A TABLE STAND – YOUR PLACE!

A screen on the reception desk, at the cash desk, or right next to you at your own desk. SMS has everything you need – from columns in different lengths to fixtures and designed supporting brackets.

### THREE WEIGHT CLASSES ARE AVAILABLE

**HEAVY WEIGHT, H**  
100 kg ~37-50"

**MIDDLE WEIGHT, M**  
30 kg ~26-37"

**LIGHT WEIGHT, L**  
15 kg ~15-26"



**SWIVEL AND TILT FOR AN IMPROVED IMAGE**

SMS FLATSCREEN TL ST  
Art no: FS061-series

### WHO IS TO VIEW THE SCREEN?

Turn the screen towards different viewers using our flexible 3D arm.

3D arm L  
Art no: FS040014

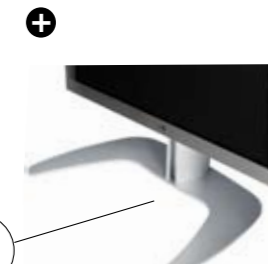

**AVOID DRILLING HOLES**  
Use the boomerang foot.

# THE RELIABLE FUNC RANGE.

**FUNC** Func is our simpler solution, a smart basic range that focuses on function and safety.

### THREE WEIGHT CLASSES ARE AVAILABLE

**HEAVY WEIGHT, H**  
100 kg ~37-50"

**MIDDLE WEIGHT, M**  
30 kg ~26-37"

**LIGHT WEIGHT, L**  
15 kg ~15-26"



**TESTED BY KTH\***  
A wall bracket that allows the screen to be tilted forwards. For screens up to 30 kg.

FUNC FLATSCREEN WM/WH T  
Art no: FS011002, FS011020/  
PL020021, PL020020

Easy to adjust to a suitable length.

**FOR SLOPING CEILINGS**  
Can be used for sloping ceilings, and allows two screens to be mounted on one column. For screens up to 100 kg.

FUNC FLATSCREEN CH VSTD2  
Art no: PL061-series

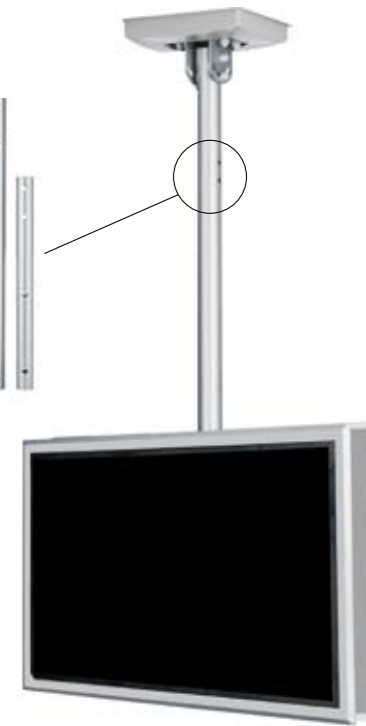

\*The Royal Institute of Technology

# BRING YOUR PROJECTOR TO NEW HEIGHTS.

Choose a sure method of getting more from your projector. All of our products are easy to mount, easy to adjust, and easy to like.



**CEILING COVER**

Cover the ceiling plate and screws with the matching grey cover.



**ATTACH BY GRIPPING**

If no other mounting methods can be used, this accessory can be used to support screens or projectors up to 15 kg.

SMS CLAMP  
Art no: FS040013



**SEVERAL LENGTHS**

Can be supplied in several lengths, most of which can be cut to size.

SMS PROJECTOR CL F  
Art no: AE014-series



**CONCEAL THE CABLES**

An integral cable holder conceals the cables.

**NB!**



Conceal all the cables with SMS Cable Management. See Page 35.

- Suitable for most projectors, display environments and ceiling heights.
- We have projector brackets for ceilings, walls and floors.
- Ample adjustment possibilities to ensure the best possible image.



**INVISIBLE**

Hidden in the ceiling when not in use. Theft-proof. Short operating distance, only 130 mm.

SMS SECRET  
Art no: LI010-series



**LAPTOP SHELF**

Used when you need to place the projector and your laptop together during the presentation. Up to five shelves.

SMS PROJECTOR STANDUP FM2  
Art no: SU021-series



**WALL-MOUNTED SHELF**

This can be used if it is not possible to suspend the projector upside down from the ceiling.

SMS PROJECTOR WL F  
Art no: AE013-series



**WALL MOUNTING**

This bracket can hold the projector, up to 12 kg, an arm's length from the wall.

SMS PROJECTOR WL V  
Art no: AE013-series



## Updated!

**ADJUSTABLE**

Enhance your image with our classical projector bracket, most popular with our customers. Can be tilted and adjusted longitudinally. Now updated with a discrete ceiling cover.

SMS PROJECTOR CL V  
Art no: AE012-series



? Need help in choosing a bracket? See Page 42. + Technical information is available at [www.smartmediasolutions.se](http://www.smartmediasolutions.se)

**NB!**

## HOW TO OBTAIN INFORMATION ABOUT ALL OUR PRODUCTS.

Complete news and information about all of our products, including technical specifications, drawings, instructions for mounting, article numbers, accessories, etc., can be found on our website: [www.smartmediasolutions.se](http://www.smartmediasolutions.se)

### A QUICK GUIDE TO OUR NAMING SYSTEM.

Follow the five steps below to derive the name of the bracket that suits your needs. There is some useful information at the bottom of the page about screen sizes and the terms we use.

1	2	3	4	5
BRAND?	TO BE USED FOR?	LOCATION?	SIZE OR WEIGHT OF SCREEN?	FUNCTIONS REQUIRED?
Func SMS	Projector	Ceiling, C (Ceiling suspension)	Heavy weight, H Screen size approx. 37-50" Screen weight: +30 kg	Fixed, F (Fixed)
		Floor, F (Floor standing)	Middle weight, M Screen size approx. 26-37" Screen weight up to 30 kg	Swivel, S (Can be swivelled)
	Flatscreen	Table, T (Table mounting)	Light weight, L Screen size approx. 15-26" Screen weight up to 15 kg	Tilt, T (Can be tilted)
		Wall, W (Wall mounting)		Mobile, M (With wheels)
				Variable, V (Variable length)
				Double, D (Double screens)
				Hidden, H (Hidden)
				3D, 3D (Arm protruding from wall)



SMS Flatscreen WL 3D





[www.smartmediasolutions.se](http://www.smartmediasolutions.se)

---

CONTACT FOR MORE INFORMATION: